

INSTALLATION MANUAL

38160A

ecolight



UGR19

90
CRI



230V | SMD 2835 | 40W | IP20 | Aluminium
Complete with 1000mA driver / Optional suspension kit 050170.



1200mm

75mm

one
LIGHT

A SURFACE INSTALLATION

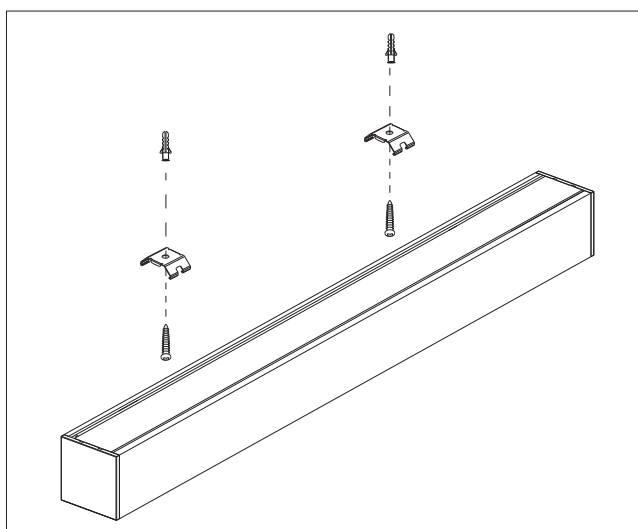

B SUSPENDED INSTALLATION

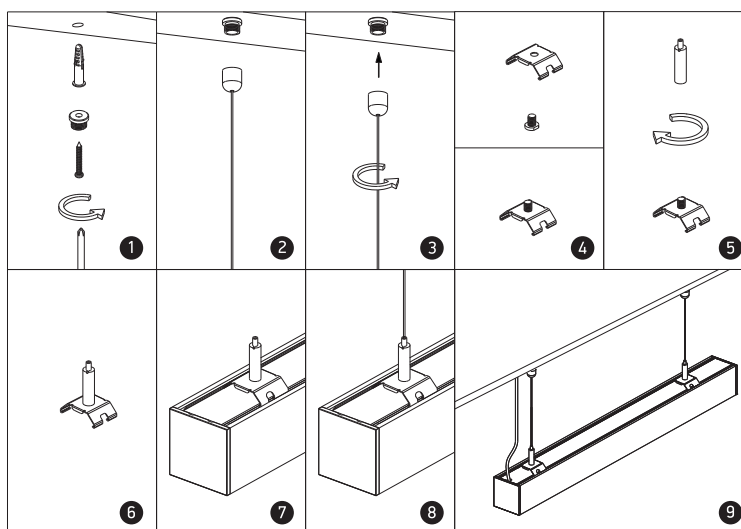

C CONNECTION

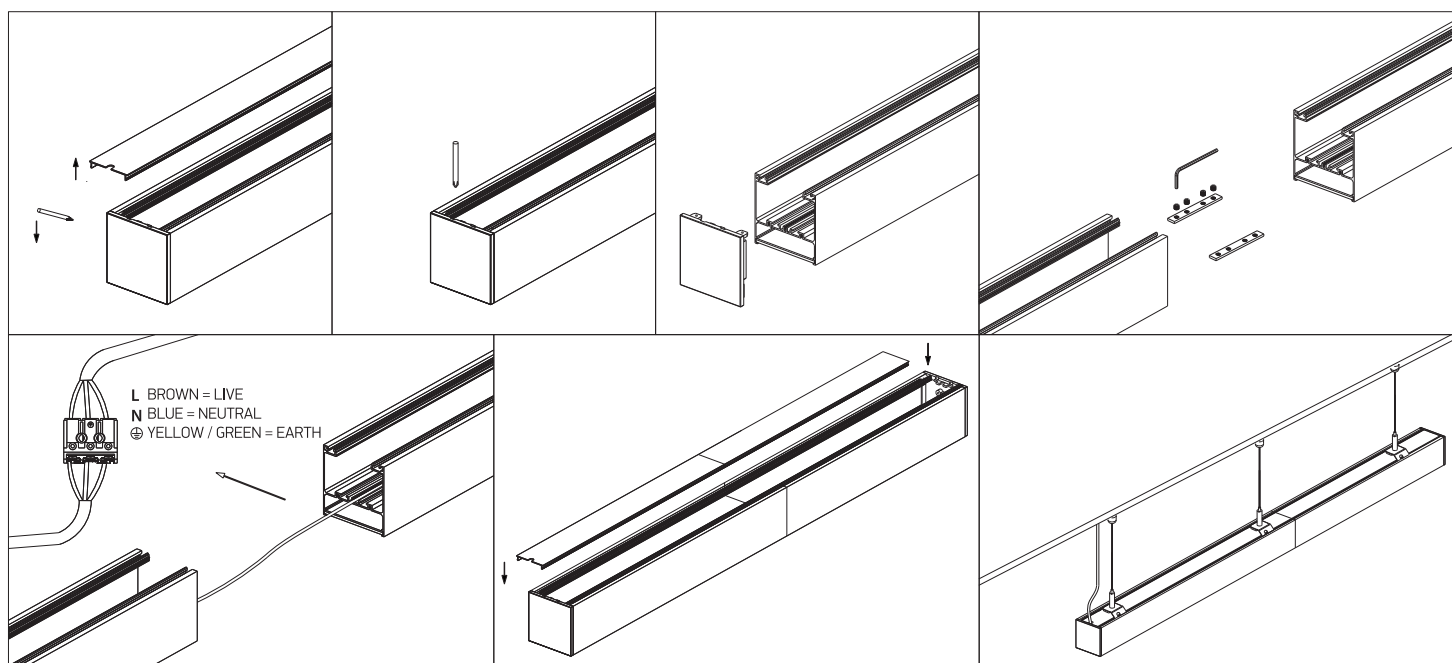

Warnings:

1. Make sure that the product is installed properly before connecting to electricity.
2. Do not cover the fitting.
3. Maintenance and installation should only be carried out by a professional electrician.